

ART. 75

Raccordi a "T", aisi 316 / A4

Tees pipe fittings, aisi 316 / A4

Esecuzione: Microfusione

Execution: Microcasting

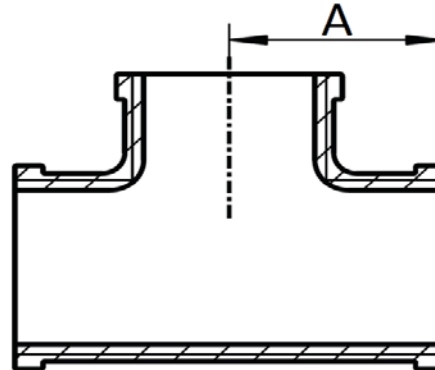

Filettatura: conforme a EN 10226-1 (EX ISO 7-1)
(filetto maschio conico, filetto femmina cilindrico)

Conicità 1:16 sul diametro

Angolo del filetto 55°

Pressione massima d'esercizio 150 Lbs (Libbre) = 10,34 BAR PN10

Thread: according to EN 10226-1 (EX ISO 7-1)

(conical male thread, cylindric female thread)

Taper 1:16 on diameter

Angle of threads 55°

Maximum operating pressure 150 lbs = 10,34 Bar PN 10



Codice Articolo <i>Item Number</i>	M <i>size</i>	DN/ID	A (mm)	Box	Master carton
00750001804	1/8"	6	14	5	200
00750001404	1/4"	8	18,5	5	250
00750003804	3/8"	10	20,8	5	100
00750001204	1/2"	15	25	5	75
00750003404	3/4"	20	27,5	5	100
00750010004	1"	25	33	5	40
00750011404	1"1/4	32	39,5	5	25
00750011204	1"1/2	40	43	5	20
00750020004	2"	50	52	1	10
00750040004	4"	100	89	1	/